

# ALLEN PRISIONERO SIN CABEZA CALIDAD 12.9 MÉTRICO

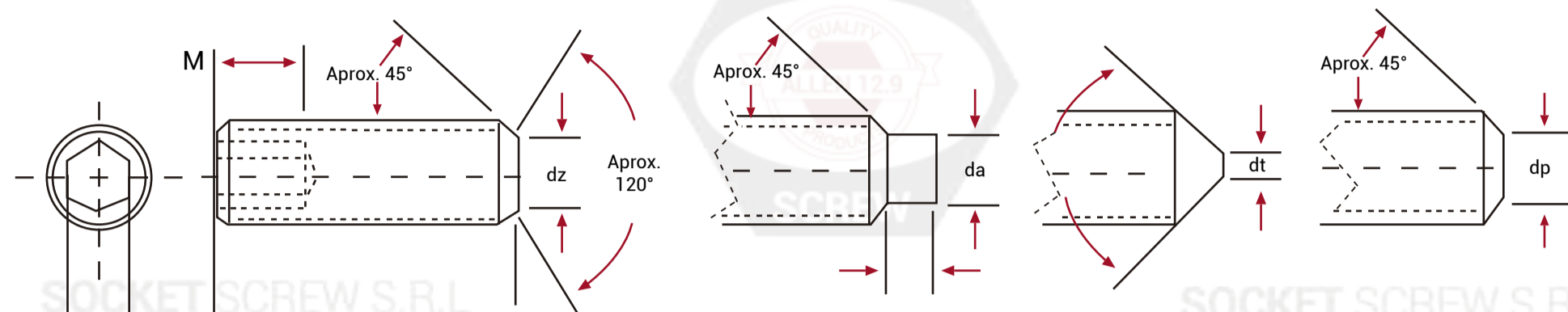

## Dimensiones (mm)

Nom Size	M (Flat Point)		M (Cup Point)		M (Cone Point)		M (Dog Point)		Z
	Length	min	Length	min	Length	min	Length	min	
M3	L ≤ 3	1.20	L ≤ 4	1.20	L ≤ 4	1.20	L ≤ 5	1.20	0.75 - 1.00
	L > 3	2.00	L > 4	2.00	L > 4	2.00	L > 5	2.00	1.50 - 1.75
M4	L ≤ 4	1.50	L ≤ 5	1.50	L ≤ 5	1.50	L ≤ 6	1.50	1.00 - 1.25
	L > 4	2.50	L > 5	2.50	L > 5	2.50	L > 6	2.50	2.00 - 2.25
M5	L ≤ 5	2.00	L ≤ 5	2.00	L ≤ 5	2.00	L ≤ 6	2.00	1.25 - 1.50
	L > 5	3.00	L > 5	3.00	L > 5	3.00	L > 6	3.00	2.50 - 2.75
M6	L ≤ 6	2.00	L ≤ 6	2.00	L ≤ 6	2.00	L ≤ 8	2.00	1.50 - 1.75
	L > 6	3.50	L > 6	3.50	L > 6	3.50	L > 8	3.50	3.00 - 3.25
M8	L ≤ 8	3.00	L ≤ 8	3.00	L ≤ 8	3.00	L ≤ 10	3.00	2.00 - 2.25
	L > 8	5.00	L > 8	5.00	L > 8	5.00	L > 10	5.00	4.00 - 4.30
M10	L ≤ 10	4.00	L ≤ 10	4.00	L ≤ 10	4.00	L ≤ 12	4.00	2.50 - 2.75
	L > 10	6.00	L > 10	6.00	L > 10	6.00	L > 12	6.00	5.00 - 5.30
M12	L ≤ 12	4.80	L ≤ 12	4.80	L ≤ 12	4.80	L ≤ 16	4.80	3.00 - 3.25
	L > 12	8.00	L > 12	8.00	L > 12	8.00	L > 16	8.00	6.00 - 6.30
M14	L ≤ 14	5.60	L ≤ 14	5.60	L ≤ 14	5.60	L ≤ 20	5.60	3.50 - 3.80
	L > 14	9.00	L > 14	9.00	L > 14	9.00	L > 20	9.00	7.00 - 7.36
M16	L ≤ 16	6.40	L ≤ 16	6.40	L ≤ 16	6.40	L ≤ 20	6.40	4.00 - 4.30
	L > 16	10.00	L > 16	10.00	L > 16	10.00	L > 20	10.00	8.00 - 8.36
M18	L ≤ 18	7.20	L ≤ 18	7.20	L ≤ 18	7.20	L ≤ 25	7.20	4.50 - 4.80
	L > 18	11.00	L > 18	11.00	L > 18	11.00	L > 25	11.00	9.00 - 9.86
M20	L ≤ 20	8.00	L ≤ 20	8.00	L ≤ 20	8.00	L ≤ 25	8.00	5.00 - 5.30
	L > 20	12.00	L > 20	12.00	L > 20	12.00	L > 25	12.00	10.00 - 10.36

# ALLEN PRISIONERO SIN CABEZA CALIDAD 12.9 PULGADA

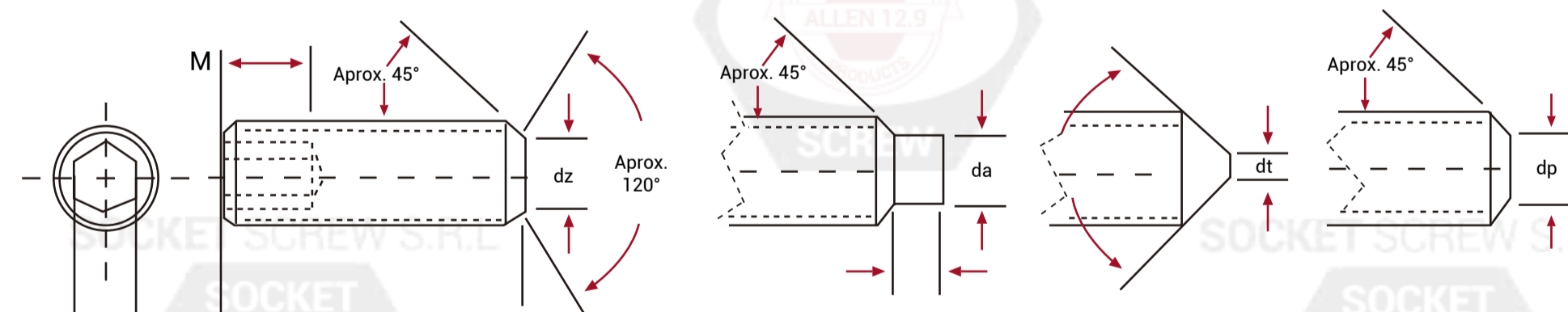

## Dimensiones (inch)

Nom Size	M (Cup & Flat Point)		M (Cone Point)		M (Dog Point)		Z
	Length	min	Length	min	Length	min	
#0	L ≥ 0.13	0.050	L ≥ 0.13	0.050	L ≥ 0.13	0.050	0.013 - 0.017
#1	L ≥ 0.13	0.060	L ≥ 0.19	0.060	L ≥ 0.13	0.060	0.017 - 0.021
#2	L ≥ 0.13	0.060	L ≥ 0.19	0.060	L ≥ 0.19	0.060	0.020 - 0.024
#3	L ≥ 0.19	0.070	L ≥ 0.19	0.070	L ≥ 0.19	0.070	0.023 - 0.027
#4	L ≥ 0.19	0.070	L ≥ 0.19	0.070	L ≥ 0.19	0.070	0.026 - 0.030
#5	L ≥ 0.19	0.080	L ≥ 0.19	0.080	L ≥ 0.19	0.080	0.027 - 0.033
#6	L ≥ 0.19	0.080	L ≥ 0.25	0.080	L ≥ 0.19	0.080	0.032 - 0.038
#8	L ≥ 0.19	0.090	L ≥ 0.25	0.090	L ≥ 0.25	0.090	0.037 - 0.043
#10	L ≥ 0.19	0.100	L ≥ 0.25	0.100	L ≥ 0.25	0.100	0.041 - 0.049
1/4	L ≥ 0.25	0.125	L ≥ 0.31	0.125	L ≥ 0.31	0.125	0.059 - 0.067
5/16	L ≥ 0.31	0.156	L ≥ 0.44	0.156	L ≥ 0.38	0.156	0.074 - 0.082
3/8	L ≥ 0.38	0.188	L ≥ 0.44	0.188	L ≥ 0.44	0.188	0.089 - 0.099
7/16	L ≥ 0.44	0.219	L ≥ 0.63	0.219	L ≥ 0.50	0.219	0.104 - 0.114
1/2	L ≥ 0.50	0.250	L ≥ 0.63	0.250	L ≥ 0.63	0.250	0.120 - 0.130
5/8	L ≥ 0.63	0.312	L ≥ 0.88	0.312	L ≥ 0.88	0.312	0.148 - 0.164
3/4	L ≥ 0.75	0.375	L ≥ 1.00	0.375	L ≥ 1.00	0.375	0.180 - 0.196
7/8	L ≥ 0.88	0.500	L ≥ 1.00	0.500	L ≥ 1.00	0.500	0.211 - 0.227
1"	L ≥ 1.00	0.562	L ≥ 1.25	0.562	L ≥ 1.25	0.562	0.240 - 0.260